

# ES SERIES

ELECTRIC SCISSOR LIFTS



## Performance

Platform Height–Elevated		
1930ES	5.72 m	
2032ES	6.10 m	
2632ES	7.77 m	
2646ES	7.92 m	
3246ES	9.68 m	
Platform Capacity		
1930ES	230 kg	
2032ES	360 kg	
2632ES	230/360 kg	
2646ES	450 kg	
3246ES	320/450 kg	
Capacity on Platform Extension	120 kg	
Lift/Lower Time		
1930ES	26/30 seconds	
2032ES	28/40 seconds	
2632ES	33/37 seconds	
2646ES	41/50 seconds	
3246ES	55/62 seconds	
Maximum Drive Height	Fully Elevated	
Weight*		
1930ES	1,575 kg	
2032ES	2,000 kg	
2632ES	2,145 kg	
2646ES	2,765 kg	
3246ES	2,940 kg	
Drive Speed–Elevated	0.8 km/h	
Drive Speed–Lowered		
1930ES	4.82 km/h	
2032ES/ 2632ES	4.43 km/h	
2646ES/ 3246ES	4.00 km/h	
Gradeability	25%	
Turning Radius (Inside)	Zero	
Turning Radius (Outside)		
1930ES	1.75 m	
2032ES/ 2632ES	2.06 m	
2646ES/ 3246ES	2.41 m	

\* Certain options or country standards will increase weight.

## Standard Specifications

### Power Source

Batteries	4x6V 220 amp-hr	
Charger	20 Amp Automatic	
Drive	24V Electric	8hp

### Hydraulic Reservoir

• Capacity		
1930ES/2032ES/2632ES	4.73 L	
2646ES/3246ES	6.4 L	
• Pump	Fixed Displacement Gear	

### Tyres

• Tyre Size/Type		
1930ES	12.5 x 4 in. Non-Marking Solid	
2032ES/2632ES/2646ES/3246ES	16 x 5 in. Non-Marking Solid	

### Brakes

- Electric/Friction



## Standard Features

- Proportional Controls
- Industry Leading Duty Cycles
- Self Closing and Locking Gate
- Battery Condition Indicator
- Fold-Down Guard Rails<sup>1</sup>
- Slide-Out Battery Trays
- Automatic Traction Control (ATC)
- All Motion Alarm
- 20 Amp Automatic SCR Charger
- Horn
- Hourmeter
- Manual Descent Pull Cable
- Tilt Alarm and Light
- Moveable, Removable Platform Control
- Powder-Coated
- Console with Rail Mounting Bracket
- Nickel Plated Pins
- Lubrication Free Scissor Arm Bushings
- Scissor Maintenance Prop
- Mechanised Pothole Protection
- Machine Tie Downs
- Fork Lift Pockets, Lift from Side and Rear
- Flashing Amber Beacon
- Load Sensing System
- Lifting Lugs

## Accessories & Options

- AC Outlet in Platform
- White Noise (squawker) Motion Alarm
- AGM Batteries
- Airline to Platform
- Special Hydraulic Oils
- Accessory Packages:
  - Electrician's Package
  - Plumber's Package
  - JLG® Workstation
  - Panel Carrier Accessory<sup>1</sup>
  - Pipe Rack Accessory<sup>1</sup>
  - Plant Maintenance Package

1. Not available on the 1930ES.

# ES SERIES

ELECTRIC SCISSOR LIFTS

**JLG**  
reachingout®

## Dimensions

All dimensions are approximate.

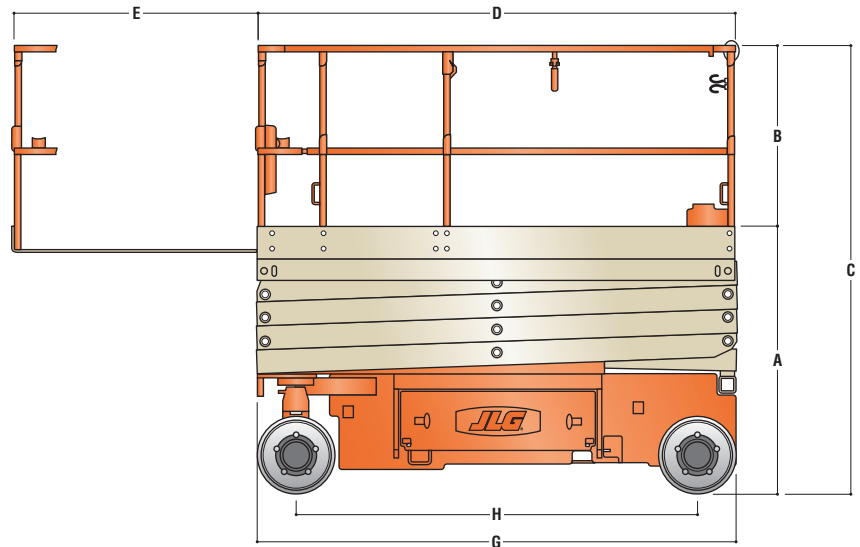
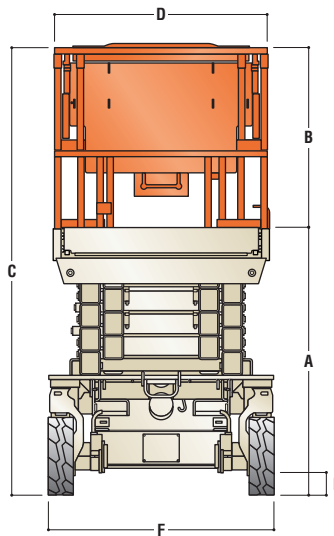

### A. Platform Height—Lowered

1930ES	0.86 m
2032ES	1.10 m
2632ES	1.23 m
2646ES	1.26 m
3246ES	1.26 m

### B. Platform Railing Height

ES Series	1.14 m
-----------	--------

### C. Overall Height—Rails Lowered

1930ES	N/A
2032ES	1.80 m
2632ES	1.94 m
2646ES/3246ES	1.97 m

### D. Platform Size

1930ES	0.76 x 1.87 m
2032ES/2632ES	0.76 x 2.3 m
2646ES/3246ES	1.12 x 2.5 m

### E. Platform Extension

1930ES/2032ES/2632ES	0.9 m
2646ES/3246ES	1.27 m

### F. Overall Width

1930ES	76 cm
2032ES/2632ES	81 cm
2646ES/3246ES	1.17 m

### G. Overall Length

1930ES	1.87 m
2032ES/2632ES	2.3 m
2646ES/3246ES	2.5 m

### H. Wheelbase

1930ES	1.6 m
2032ES/2632ES	1.88 m
2646ES/3246ES	2.09 m

### I. Ground Clearance

1930ES/2032ES/2632ES	8.8 cm
2646ES/3246ES	12.7 cm



[www.jlg.com.au/ES-Scissor1](http://www.jlg.com.au/ES-Scissor1)

**JLG**  
reachingout®

## The JLG "2 & 5" Warranty

JLG Industries, Inc. backs its products with its exclusive "2 & 5" Warranty. We provide coverage on all products for two (2) full years and cover all specified major structural components for five (5) years. Due to continuous product improvements, we reserve the right to make specification and/or equipment changes without prior notification. This machine meets or exceeds AS/NZS 1418.10 2011 as originally manufactured for intended applications.

### JLG Industries (Australia)

358 Park Road  
Regents Park, NSW 2143  
Telephone 02 8718 6300  
Fax 02 8718 6377

[www.jlg.com.au](http://www.jlg.com.au)

An Oshkosh Corporation Company